

MAGSON MML - 2

Magnetically coupled centrifugal pumps
made of stainless steel



More than just pumps



MML type 2



- Sealless
- Robust and casted casing
- Temperatures up to 150 °C
(higher temp. on request)
- Close coupled, single stage, horizontal back-pullout-design
- Flange connection according to DIN
- Suction side DN 40
- Discharge side DN 25

Characteristic curves

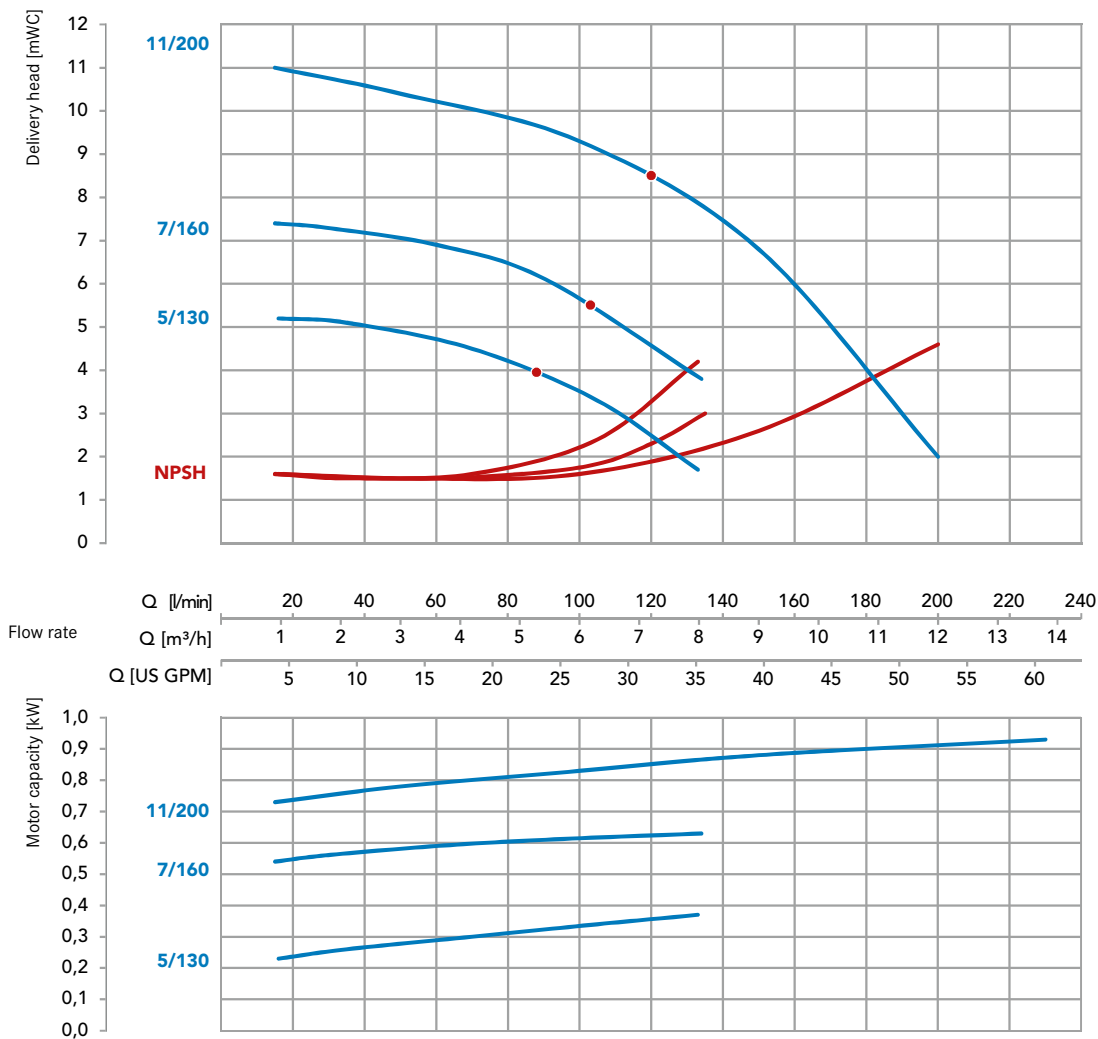

Technical data MML BG2

Type	5/130		7/160		11/200	
Material	Stainless steel 1.4408 (CF8M/AISI 316L)					
Max. delivery head [mWC] 50 Hz	5		7		11	
Max. volume flow in [l/min] 50 Hz	130		160		200	
Max. density in [g/cm ³] 50 Hz *	2	2,9	1,2	1,8	1,2	1,6
Motor capacity [kW]	0,75	1,1	0,75	1,1	1,1	1,5
Current rating (400 V, 50 Hz) [A] **	1,56	2,25	1,56	2,25	2,25	3
Rated speed in [rpm] 50 Hz	3000					
Suction port	DN 40					
Discharge port	DN 25					
Voltage in [V] ***	230/400					
Protection class	IP55					
Max. flow velocity [m/s]	Suction side 1 / discharge side 3					
Max. system pressure [bar]	16 / optional 25					
Max. temperature [°C]	150					

* approx. at max. volume flow (higher density possible when flow rate is reduced)

** depends on motor supplier

*** other voltages on request

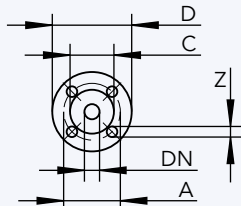
	Dimensions [mm]	Connections DIN EN 1092-1		Length of motor		
		Suction	Discharge	0,75 kW	1,1 kW	1,5 kW
Dimension A	110	85				
Dimension C	88	68				
Dimension D	150	115				
Dimension DN	40	25				
Dimension L*				252	287	297
Dimension Z	18	14				

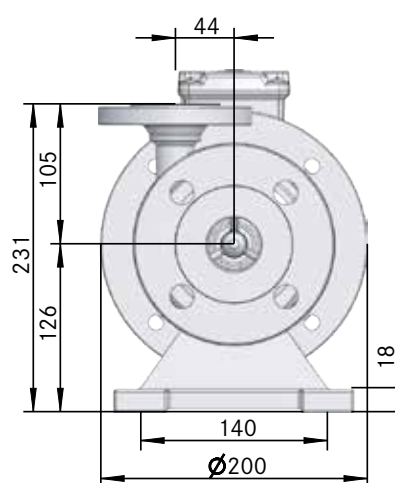
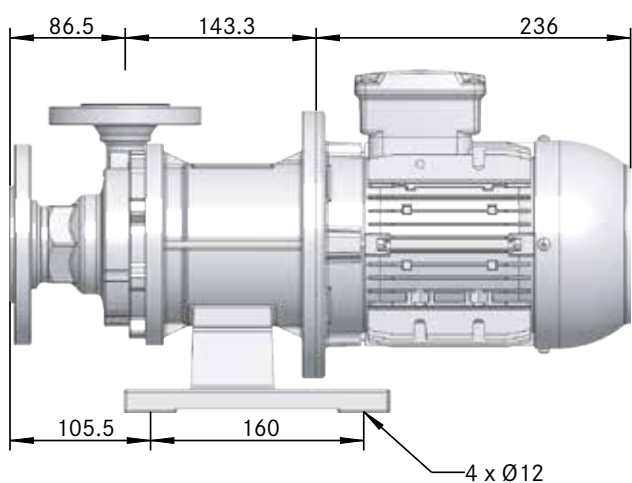

* Motor dimensions may differ according to manufacturer.



More than just pumps

FLUX is a world renowned brand for the highest standards in pump technology. It all began in 1950 with the invention of the electric drum pump. Today, FLUX offers a wide range of products which can be configured individually. For example, FLUX pumps are used in the chemical and pharmaceutical industries, in machine and plant construction, as well as in electroplating, sewage treatment plants, and the food industry.

Whether as a stand-alone or a system solution, FLUX quality means long useful life, excellent economic efficiency and a maximum of safety.

Apart from the outstanding FLUX product quality and reliability, our clients appreciate the expertise and dedication of our employees to customer service.

Today, FLUX-GERÄTE GMBH supplies pumps to almost one hundred countries world wide.

FLUX-GERÄTE GMBH

Process Pumps & Systems
August-Horch-Straße 2 · 51149 Köln
Postfach 920101 · 51151 Köln

Tel. +49 2203 9394-0
Fax +49 2203 9394-48

info-process@flux-pumpen.de
www.flux-pumps.com